

Experiment 4: Resistances in Circuits

EQUIPMENT NEEDED:

- Circuits Experiment Board
- Multimeter
- Resistors.

Purpose

The purpose of this lab is to begin experimenting with the variables that contribute to the operation of an electrical circuit. This is the first of a three connected labs.

Procedure

- ① Choose the three resistors having the same value. Enter those sets of colors in Table 4.1 below. We will refer to one as #1, another as #2 and the third as #3.
- ② Determine the coded value of your resistors. Enter the value in the column labeled "Coded Resistance" in Table 4.1. Enter the Tolerance value as indicated by the color of the fourth band under "Tolerance."
- ③ Use the Multimeter to measure the resistance of each of your three resistors. Enter these values in Table 4.1.
- ④ Determine the percentage experimental error of each resistance value and enter it in the appropriate column.

$$\text{Experimental Error} = [(|\text{Measured} - \text{Coded}|) / \text{Coded}] \times 100\%$$

	Colors				Coded Resistance	Measured Resistance	% Error	Tolerance
	1st	2nd	3rd	4th				
#1								
#2								
#3								

Table 4.1

- ⑤ Now connect the three resistors into the SERIES CIRCUIT, figure 4.1, using the spring clips on the Circuits Experiment Board to hold the leads of the resistors together without bending them. Measure the resistances of the combinations as indicated on the diagram by connecting the leads of the Multimeter between the points at the ends of the arrows.

Series

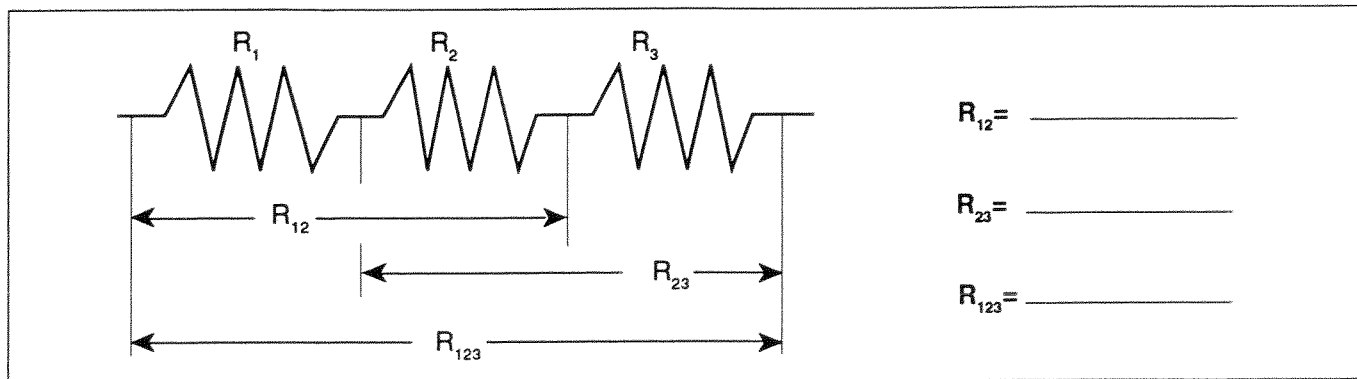

Figure 4.1

- ⑥ Construct a PARALLEL CIRCUIT, first using combinations of two of the resistors, and then using all three. Measure and record your values for these circuits.

Parallel

►NOTE: Include also R_{13}

- ⑦ Connect the COMBINATION CIRCUIT below and measure the various combinations of resistance. Do these follow the rules as you discovered them before?

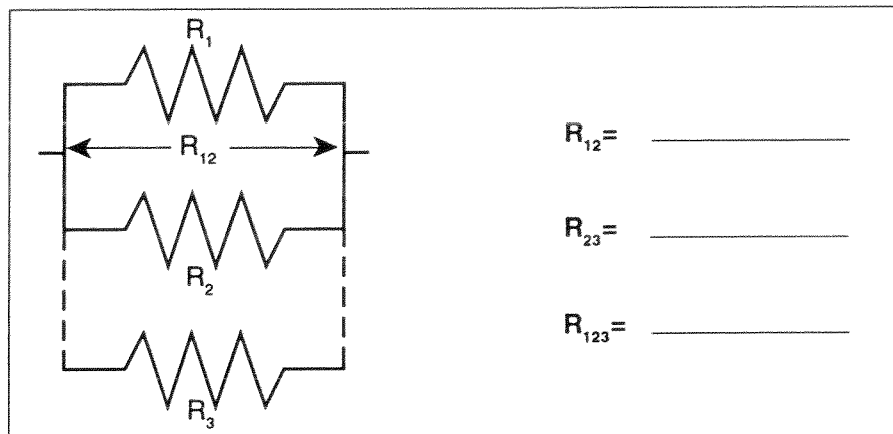

Figure 4.2

Combination

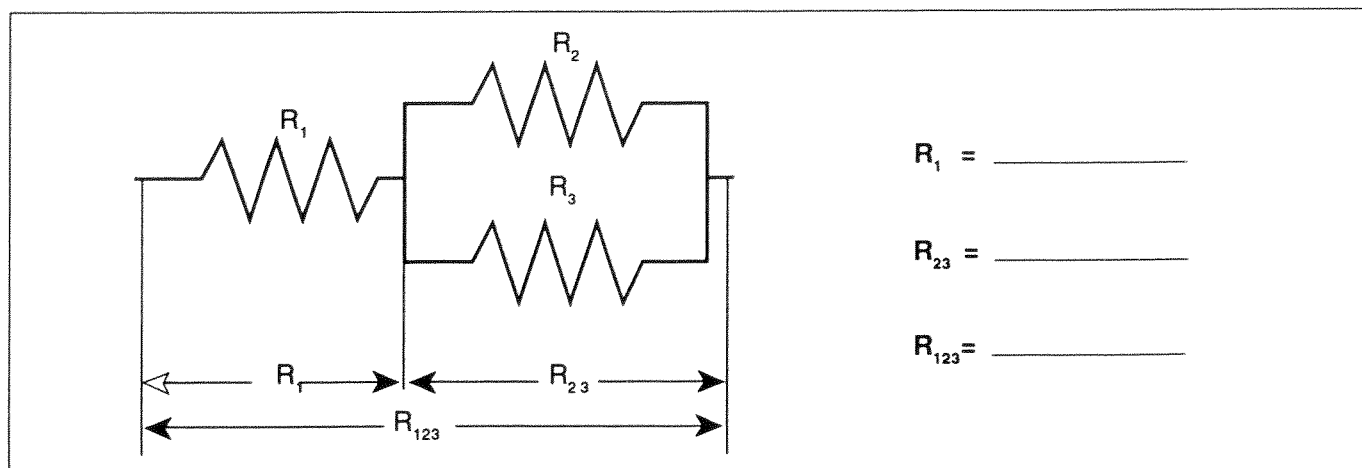

Figure 4.3

- ⑧ Choose three resistors having different values. Repeat steps 1 through 7 as above, recording your data in the spaces on the next page. Note we have called these resistors A, B and C.

	Colors				Coded Resistance	Measured Resistance	% Error	Tolerance
	1st	2nd	3rd	4th				
A								
B								
C								

Table 4.2

Series

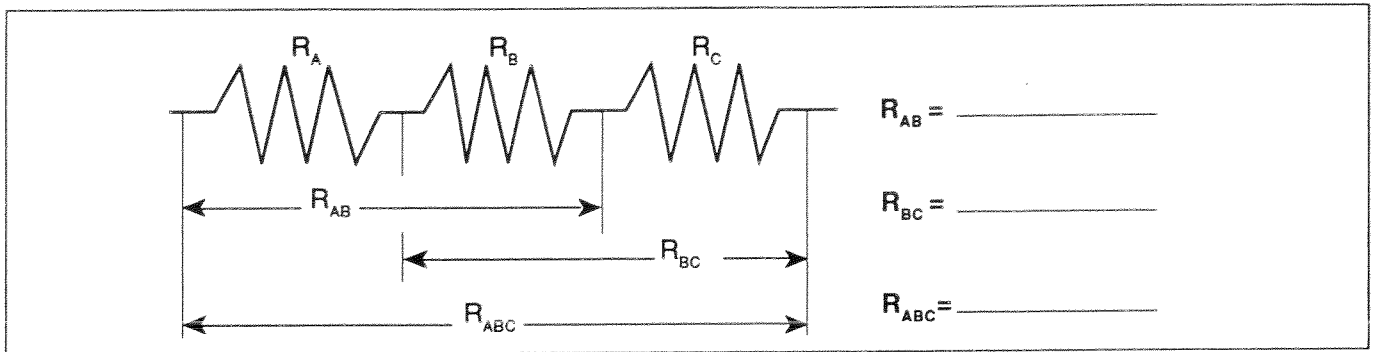

Figure 4.4

Parallel

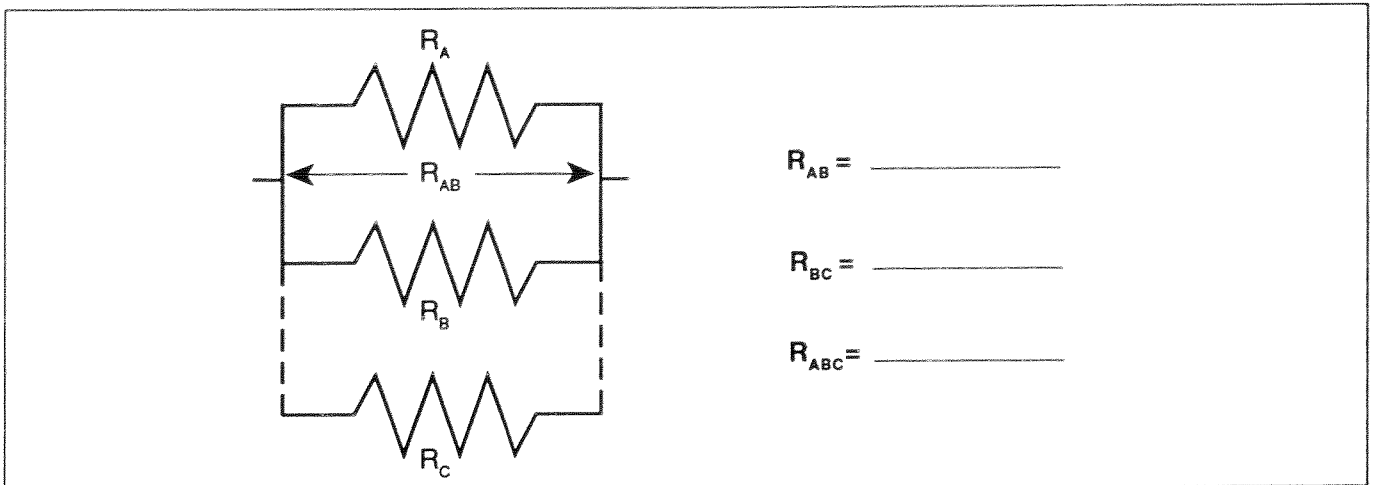

Figure 4.5

►NOTE: Include also R_{AC}

Combination

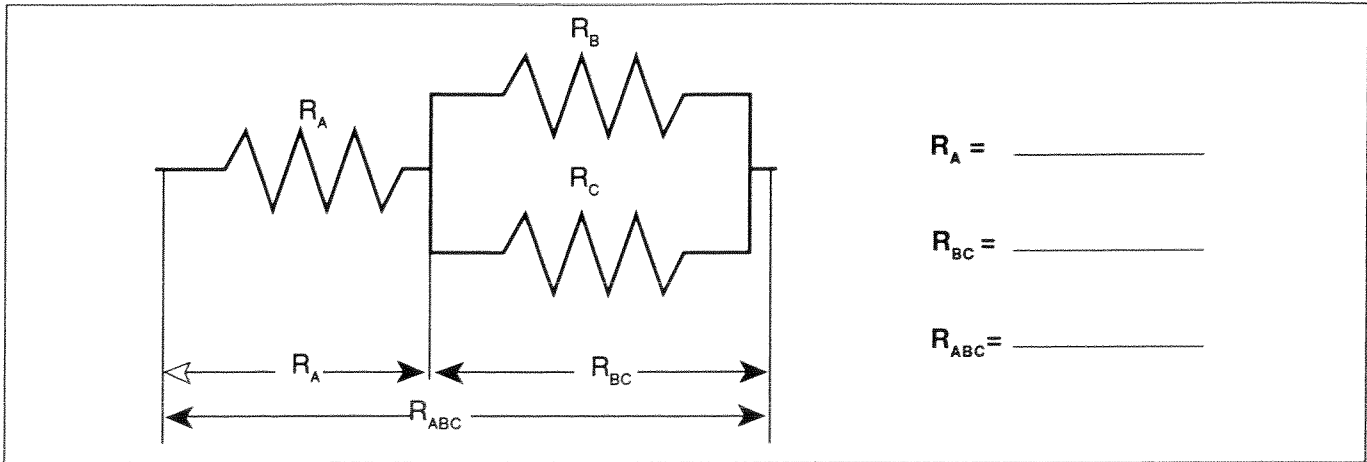

Figure 4.6

Discussion

- ① How does the % error compare to the coded tolerance for your resistors?
- ② What is the apparent rule for combining equal resistances in series circuits? In parallel circuits? Cite evidence from your data to support your conclusions.
- ③ What is the apparent rule for combining unequal resistances in series circuits? In parallel circuits? Cite evidence from your data to support your conclusions.
- ④ What is the apparent rule for the total resistance when resistors are added up in series? In parallel? Cite evidence from your data to support your conclusions.

Extension

Using the same resistance values as you used before plus any wires needed to help build the circuit, design and test the resistance values for another combination of three resistors. As instructed, build circuits with four and five resistors, testing the basic concepts you discovered in this lab.

Reference

<table border="0"> <tr><td>Black</td><td>0</td></tr> <tr><td>Brown</td><td>1</td></tr> <tr><td>Red</td><td>2</td></tr> <tr><td>Orange</td><td>3</td></tr> <tr><td>Yellow</td><td>4</td></tr> <tr><td>Green</td><td>5</td></tr> <tr><td>Blue</td><td>6</td></tr> <tr><td>Violet</td><td>7</td></tr> <tr><td>Gray</td><td>8</td></tr> <tr><td>White</td><td>9</td></tr> </table>	Black	0	Brown	1	Red	2	Orange	3	Yellow	4	Green	5	Blue	6	Violet	7	Gray	8	White	9		<table border="0"> <tr><th colspan="2" style="text-align: left;"><u>Fourth Band</u></th></tr> <tr><td>None</td><td>±20%</td></tr> <tr><td>Silver</td><td>±10%</td></tr> <tr><td>Gold</td><td>±5%</td></tr> <tr><td>Red</td><td>±2%</td></tr> </table>	<u>Fourth Band</u>		None	±20%	Silver	±10%	Gold	±5%	Red	±2%
Black	0																															
Brown	1																															
Red	2																															
Orange	3																															
Yellow	4																															
Green	5																															
Blue	6																															
Violet	7																															
Gray	8																															
White	9																															
<u>Fourth Band</u>																																
None	±20%																															
Silver	±10%																															
Gold	±5%																															
Red	±2%																															

Figure 4.7

Experiment 5: Voltages in Circuits

EQUIPMENT NEEDED:

-Circuits Experiment Board
-D-cell Battery
-Wire Leads

-Multimeter
-Resistors

Purpose

The purpose of this lab will be to continue experimenting with the variables that contribute to the operation of an electrical circuit. You should have completed Experiment 4 before working on this lab.

Procedure

- ① Connect the three equal resistors that you used in Experiment 4 into the series circuit shown below, using the springs to hold the leads of the resistors together without bending them. Connect two wires to the D-cell, carefully noting which wire is connected to the negative and which is connected to the positive.
- ② Now use the voltage function on the Multimeter to measure the voltages across the individual resistors and then across the combinations of resistors. Be careful to observe the polarity of the leads (red is +, black is -). Record your readings below.

Series

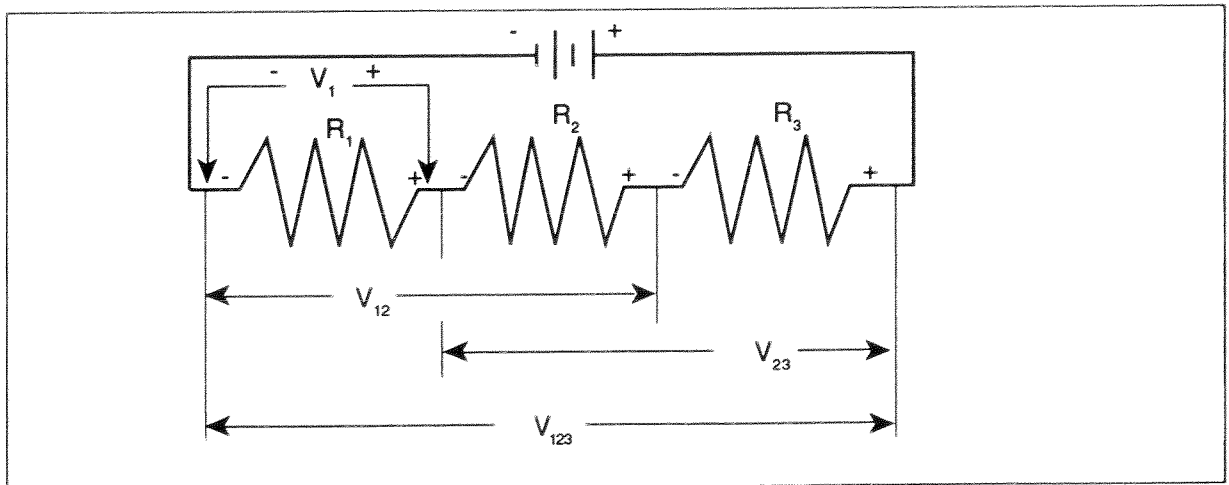

Figure 5.1

$$R_1 = \underline{\hspace{2cm}} \quad V_1 = \underline{\hspace{2cm}}$$

$$R_2 = \underline{\hspace{2cm}} \quad V_2 = \underline{\hspace{2cm}}$$

$$R_3 = \underline{\hspace{2cm}} \quad V_3 = \underline{\hspace{2cm}}$$

$$R_{12} = \underline{\hspace{2cm}} \quad V_{12} = \underline{\hspace{2cm}}$$

$$R_{23} = \underline{\hspace{2cm}} \quad V_{23} = \underline{\hspace{2cm}}$$

$$R_{123} = \underline{\hspace{2cm}} \quad V_{123} = \underline{\hspace{2cm}}$$

- ③ Now connect the parallel circuit below, *using all three resistors*. Measure the voltage across each of the resistors and the combination, taking care with the polarity as before.

►NOTE: Keep all three resistors connected throughout the time you are making your measurements. Write down your values as indicated below.

Parallel

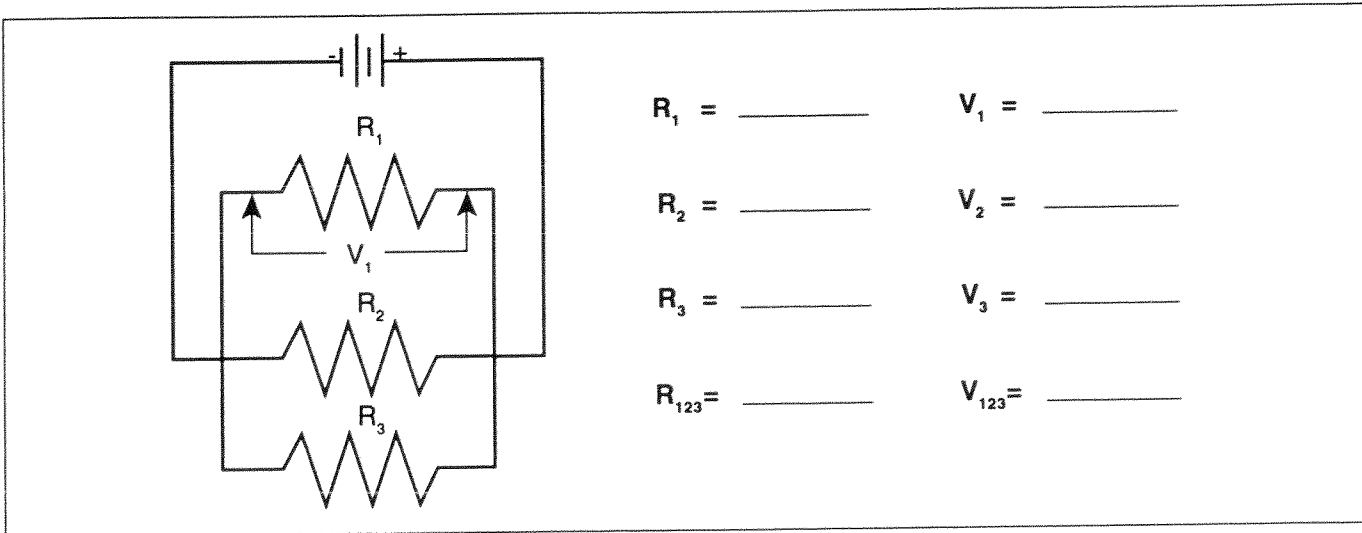

Figure 5.2

- ④ Now connect the circuit below and measure the voltages. You can use the resistance readings you took in Experiment 4 for this step.

Combination

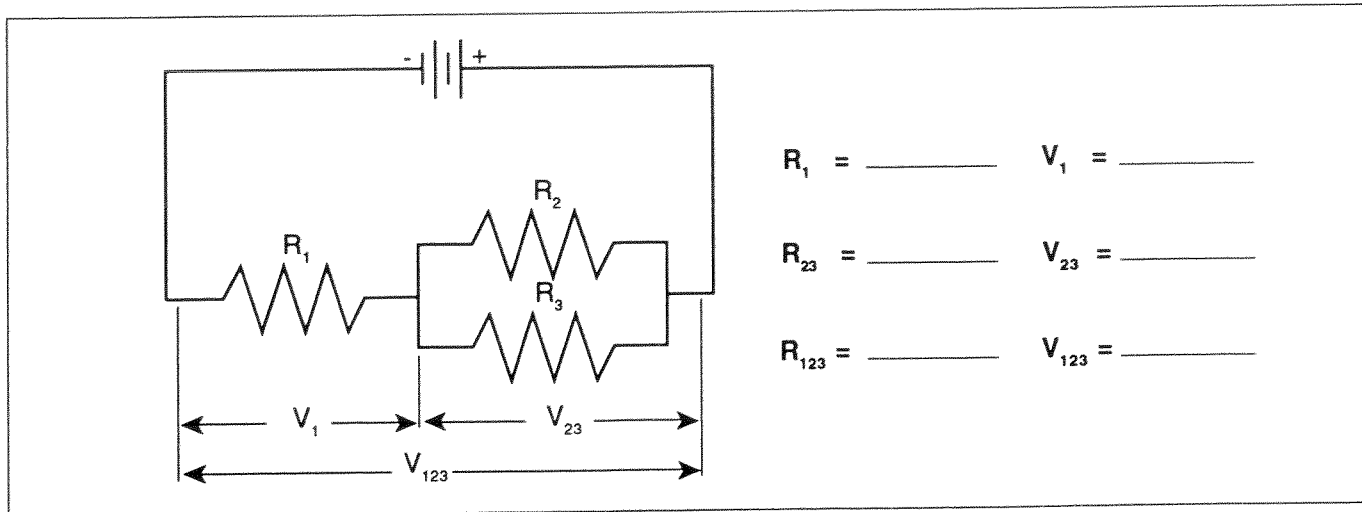

Figure 5.3

- ⑤ Use the three unequal resistors that you used in Experiment 4 to construct the circuits shown below. Make the same voltage measurements that you were asked to make before in steps 1 to 4. Use the same resistors for A, B and C that you used in Experiment 4.

Series

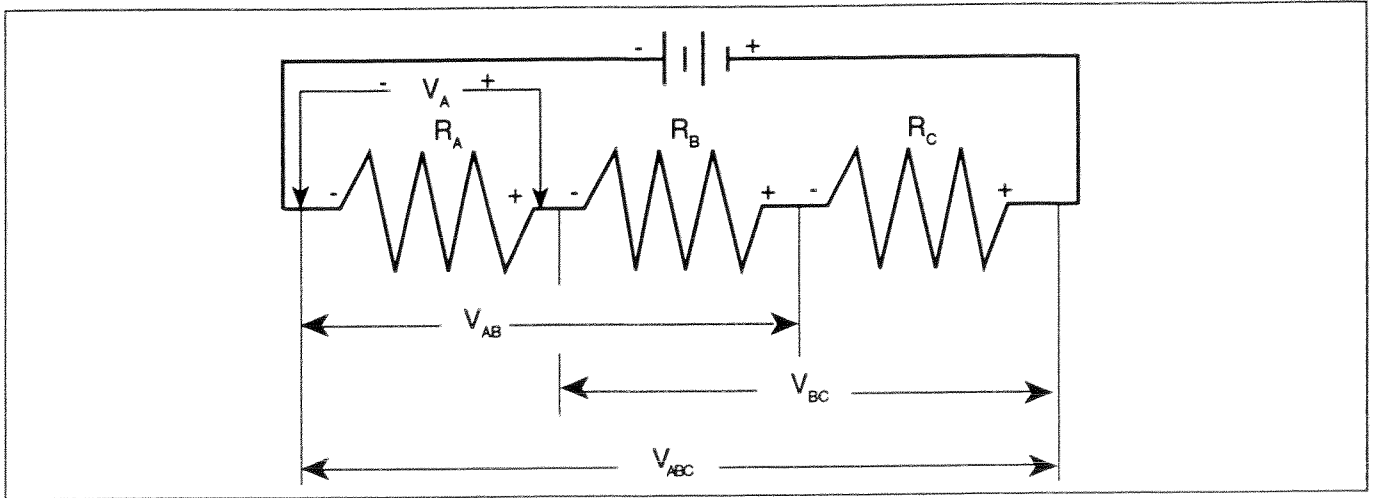

Figure 5.4

$R_A =$ _____	$V_A =$ _____
$R_B =$ _____	$V_B =$ _____
$R_C =$ _____	$V_C =$ _____
$R_{AB} =$ _____	$V_{AB} =$ _____
$R_{BC} =$ _____	$V_{BC} =$ _____
$R_{ABC} =$ _____	$V_{ABC} =$ _____

Parallel

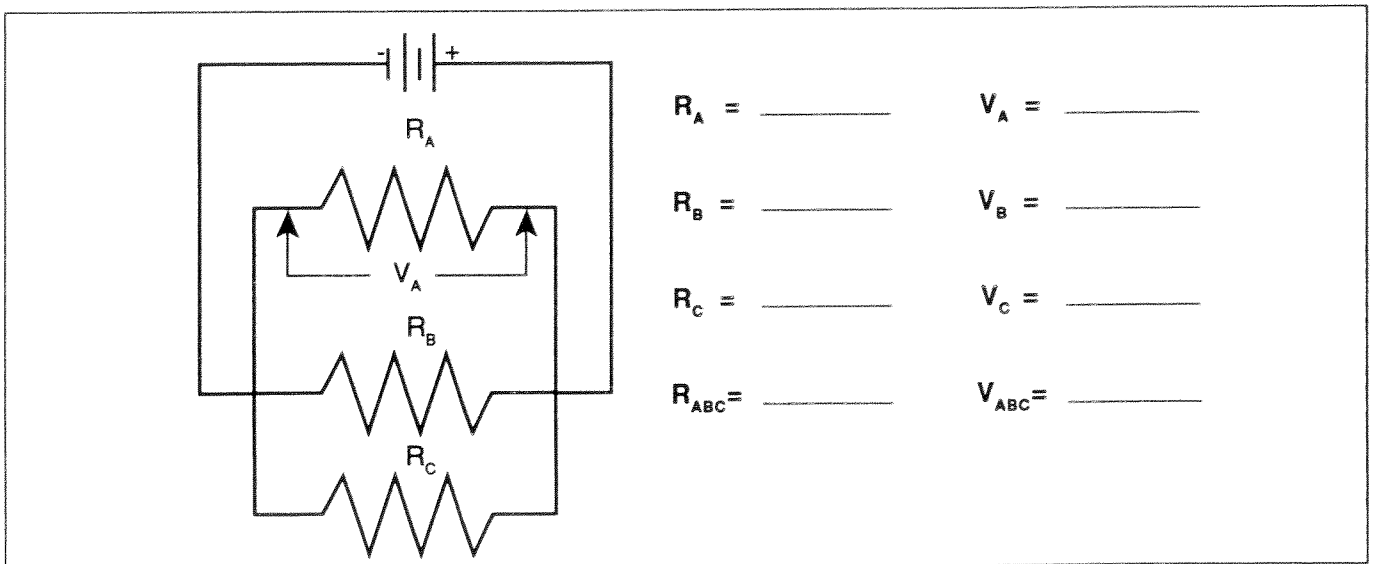

Figure 5.5

Combination

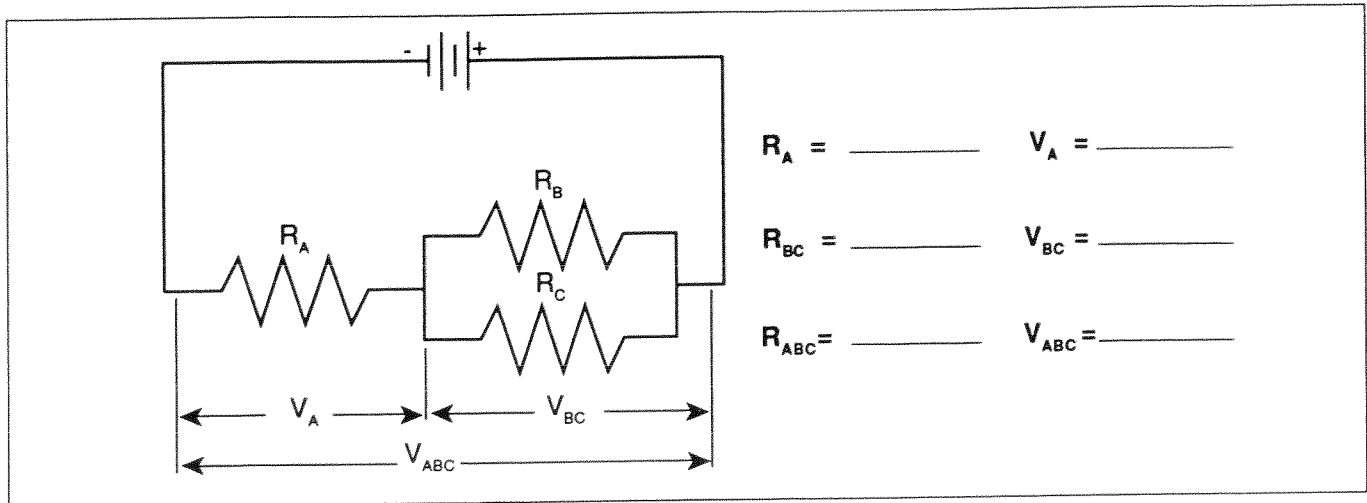

Figure 5.6

Discussion

On the basis of the data you recorded on the table with Figure 5.1, what is the pattern for how voltage gets distributed in a series circuit with equal resistances? According to the data you recorded with Figure 5.4, what is the pattern for how voltage gets distributed in a series circuit with unequal resistances? Is there any relationship between the size of the resistance and the size of the resulting voltage?

Utilizing the data from Figure 5.2, what is the pattern for how voltage distributes itself in a parallel circuit for equal resistances? Based on the data from Figure 5.5, what is the pattern for how voltage distributes itself in a parallel circuit for unequal resistances? Is there any relationship between the size of the resistance and the size of the resulting voltage?

Do the voltages in your combination circuits (see Figures 5.3 and 5.6) follow the same rules as they did in your circuits which were purely series or parallel? If not, state the rules you see in operation.

Experiment 6: Currents in Circuits

EQUIPMENT NEEDED:

- | | |
|--|--|
| <ul style="list-style-type: none"> -Circuits Experiment Board -Resistors -Wire Leads. | <ul style="list-style-type: none"> -Digital Multimeter -D-cell Battery |
|--|--|

Purpose

The purpose of this lab will be to continue experimenting with the variables that contribute to the operation of electrical circuits.

Procedure

- ① Connect the same three resistors that you used in Experiments 3 and 4 into the series circuit shown below, using the springs to hold the leads of the resistors together without bending them. Connect two wires to the D-cell, and carefully note which lead is negative and which is positive.

Series

- ② Now change the leads in your DMM so that they can be used to measure current. You should be using the scale which goes to a maximum of 200 mA. Be careful to observe the polarity of the leads (red is +, black is -). In order to measure current, the circuit must be interrupted, and the current allowed to flow through the meter. Disconnect the lead wire from the positive terminal of the battery and connect it to the red (+) lead of the meter. Connect the black (-) lead to R_1 , where the wire originally was connected. Record your reading in the table as I_0 . See Figure 6.2.

- ③ Now move the DMM to the positions indicated in Figure 6.3, each time interrupting the circuit, and carefully measuring the current in each one. Complete the table on the top of the back page.

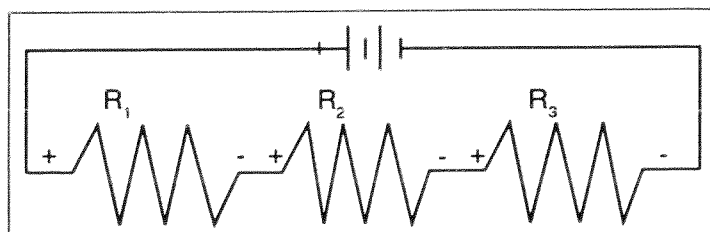

Figure 6.1

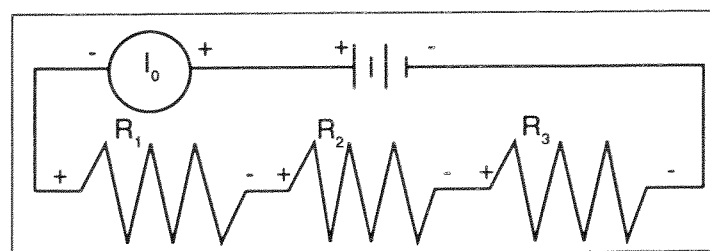

Figure 6.2

►NOTE: You will be carrying values from Experiments 3 and 4 into the table on the back.

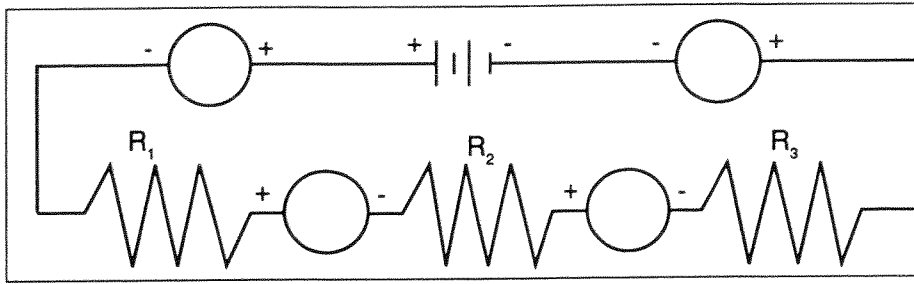

Figure 6.3

$R_1 =$ _____	$I_0 =$ _____	$V_1 =$ _____
$R_2 =$ _____	$I_1 =$ _____	$V_2 =$ _____
$R_3 =$ _____	$I_2 =$ _____	$V_3 =$ _____
$R_{12} =$ _____	$I_3 =$ _____	$V_{12} =$ _____
$R_{23} =$ _____		$V_{23} =$ _____
$R_{123} =$ _____		$V_{123} =$ _____

- ④ Connect the parallel circuit below, using all three resistors. Review the instructions for connecting the DMM as an ammeter in step 2. Connect it first between the positive terminal of the battery and the parallel circuit junction to measure I_0 . Then interrupt the various branches of the parallel circuit and measure the individual branch currents. Record your measurements in the table below.

Parallel

$R_1 =$ _____	$I_0 =$ _____	$V_1 =$ _____
$R_2 =$ _____	$I_1 =$ _____	$V_2 =$ _____
$R_3 =$ _____	$I_2 =$ _____	$V_3 =$ _____
$R_{123} =$ _____	$I_3 =$ _____	$V_{123} =$ _____
	$I_4 =$ _____	

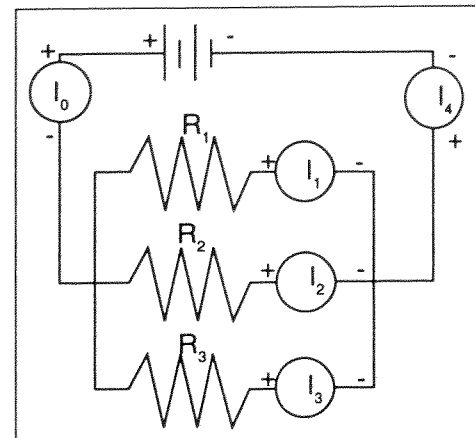

Figure 6.4

Discussion

On the basis of your first set of data, what is the pattern for how current behaves in a series circuit? At this point you should be able to summarize the behavior of all three quantities - resistance, voltage and current - in series circuits.

On the basis of your second set of data, are there any patterns to the way that currents behave in a parallel circuit? At this time you should be able to write the general characteristics of currents, voltages and resistances in parallel circuits.