

# Concept-Development Practice Page

# 35-1

## Series Circuits

1. In the circuit shown at the right, a voltage of 6 V pushes charge through a single resistor of  $2\ \Omega$ . According to Ohm's law, the current in the resistor (and therefore in the whole circuit) is \_\_\_\_\_ A.

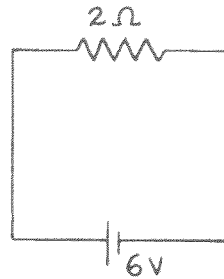

THE EQUIVALENT RESISTANCE OF RESISTORS IN SERIES IS SIMPLY THEIR SUM!

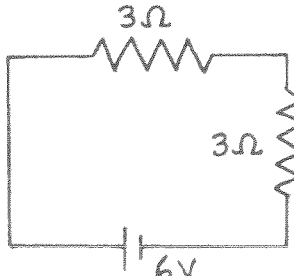

2.  If a second identical lamp is added, as on the left, the 6-V battery must push charge through a total resistance of \_\_\_\_\_  $\Omega$ . The current in the circuit is then \_\_\_\_\_ A.

3. The equivalent resistance of three  $4\text{-}\Omega$  resistors in series is \_\_\_\_\_  $\Omega$ .
4. Does current flow *through* a resistor, or *across* a resistor? \_\_\_\_\_  
Is voltage established *through* a resistor, or *across* a resistor? \_\_\_\_\_
5. Does current in the lamps occur simultaneously, or does charge flow first through one lamp, then the other, and finally the last in turn?  
\_\_\_\_\_
6. Circuits *a* and *b* below are identical with all bulbs rated at equal wattage (therefore equal resistance). The only difference between the circuits is that Bulb 5 has a short circuit, as shown.

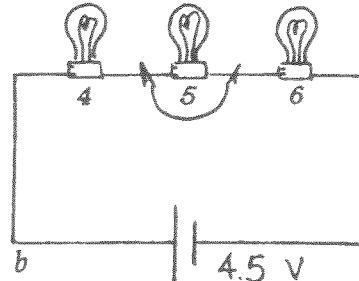
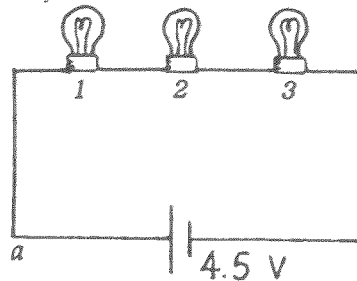

- a. In which circuit is the current greater? \_\_\_\_\_
- b. In which circuit are all three bulbs equally bright? \_\_\_\_\_
- c. What bulbs are the brightest? \_\_\_\_\_
- d. What bulb is the dimmest? \_\_\_\_\_
- e. What bulbs have the largest voltage drops across them? \_\_\_\_\_
- f. Which circuit dissipates more power? \_\_\_\_\_
- g. What circuit produces more light? \_\_\_\_\_

## Parallel Circuits

1. In the circuit shown below, there is a voltage drop of 6 V across *each* 2- $\Omega$  resistor.

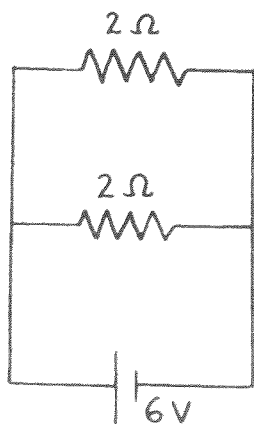

- By Ohm's law, the current in *each* resistor is \_\_\_\_\_ A.
- The current through the battery is the sum of the currents in the resistors, \_\_\_\_\_ A.
- Fill in the current in the eight blank spaces in the view of the *same* circuit shown again at the right.

THE SUM OF THE CURRENTS IN THE TWO BRANCH PATHS EQUALS THE CURRENT BEFORE IT DIVIDES.

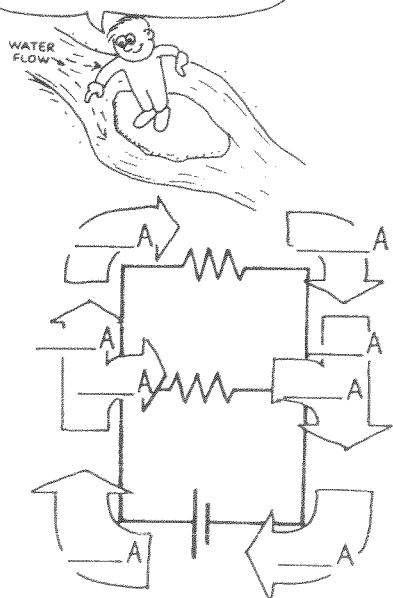

2. Cross out the circuit below that is *not* equivalent to the circuit above.

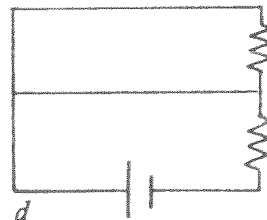
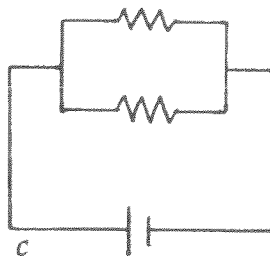
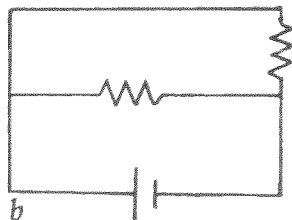
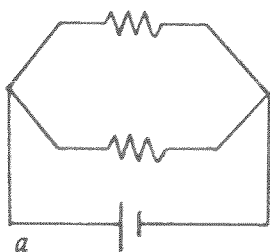

3. Consider the parallel circuit at the right.
- The voltage drop across each resistor is \_\_\_\_\_ V.

- b. The current in each branch is:

2- $\Omega$  resistor \_\_\_\_\_ A

2- $\Omega$  resistor \_\_\_\_\_ A

1- $\Omega$  resistor \_\_\_\_\_ A

- b. The current through the battery equals the sum of the currents which equals \_\_\_\_\_ A.

- c. The equivalent resistance of the circuit equals \_\_\_\_\_  $\Omega$ .

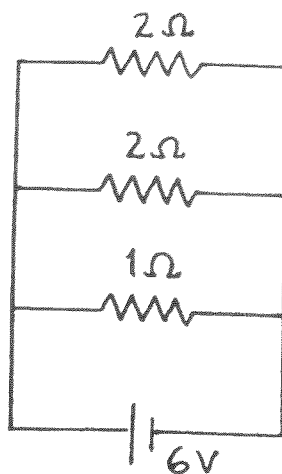

THE EQUIVALENT RESISTANCE OF A PAIR OF RESISTORS IN PARALLEL IS THEIR PRODUCT DIVIDED BY THEIR SUM!



## Concept-Development Practice Page

# 35-2

### Compound Circuits

1. The initial circuit, below left, is a compound circuit made of a combination of resistors. It is reduced to a single equivalent resistance by the three steps, the circuits to its right, *a*, *b*, *c*. In step *a*, show the equivalent resistance of the parallel 4-Ω resistors. In step *b* combine this in series with the 3-Ω resistor. In step *c*, combine the last parallel pair to obtain the equivalent resistance of the circuit. (Note the similarity of this circuit and Figure 35.10 in your textbook.)

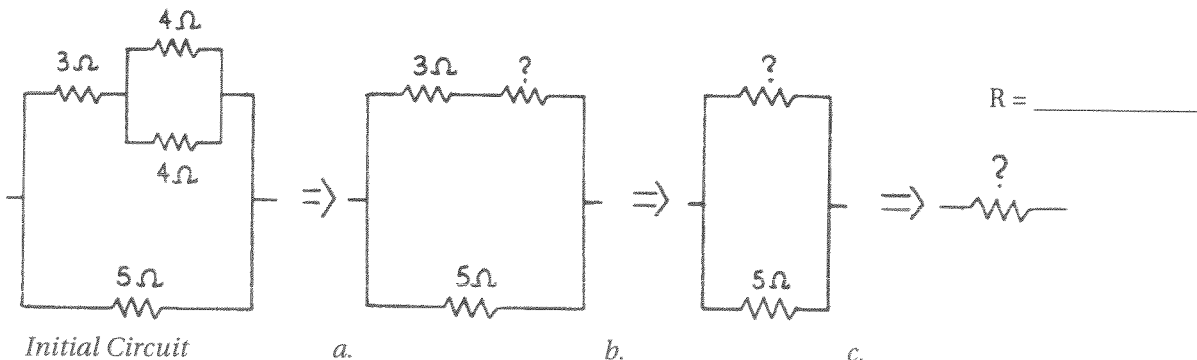

2. The circuit below is similar to Figure 35.11 in your textbook. In three successive steps, as in Question 1, replace each pair of resistors by a single resistor of equivalent resistance.



3. Find the equivalent resistance of these three circuits.

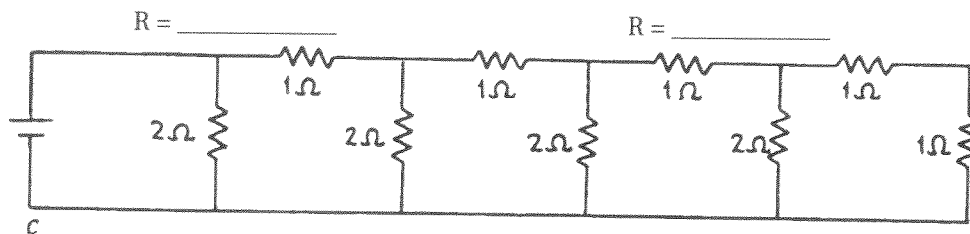
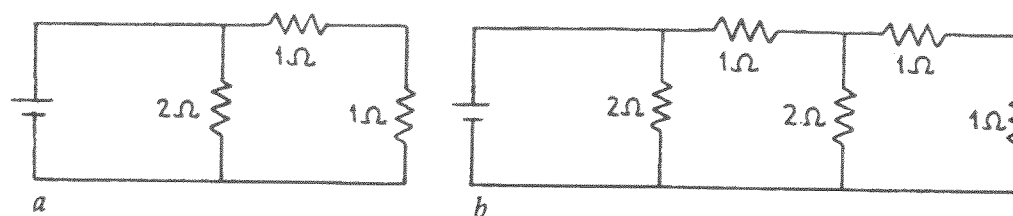

R = \_\_\_\_\_

4. The table beside circuit *a* below shows the current through each resistor, the voltage across each resistor, and the power dissipated as heat in each resistor. Find the similar correct values for circuits *b*, *c*, and *d*, and put your answers in the tables shown.

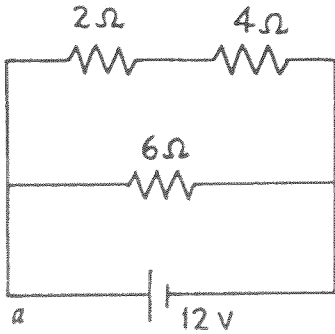

RESISTANCE	CURRENT	VOLTAGE	POWER
2 Ω	2 A	4 V	8 W
4 Ω	2 A	8 V	16 W
6 Ω	2 A	12 V	24 W

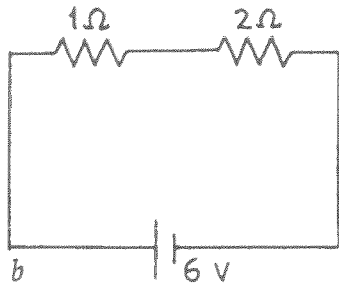

RESISTANCE	CURRENT	VOLTAGE	POWER
1 Ω			
2 Ω			

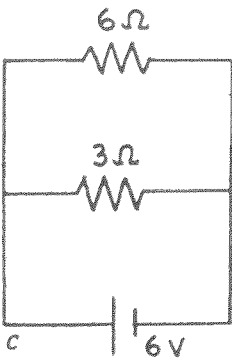

RESISTANCE	CURRENT	VOLTAGE	POWER
6 Ω			
3 Ω			

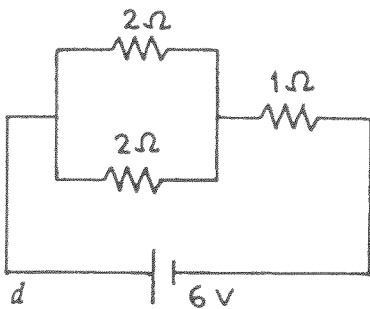

RESISTANCE	CURRENT	VOLTAGE	POWER
2 Ω			
2 Ω			
1 Ω			